

General Description

Series R4V*P2 proportional pressure relief valves are based on the mechanically adjusted Series R4V. The additional proportional unit between the mechanical pilot valve and the main stage allows continuous pressure adjustment.

The optimum performance can be achieved in combination with the digital amplifier module PCD00A-400.

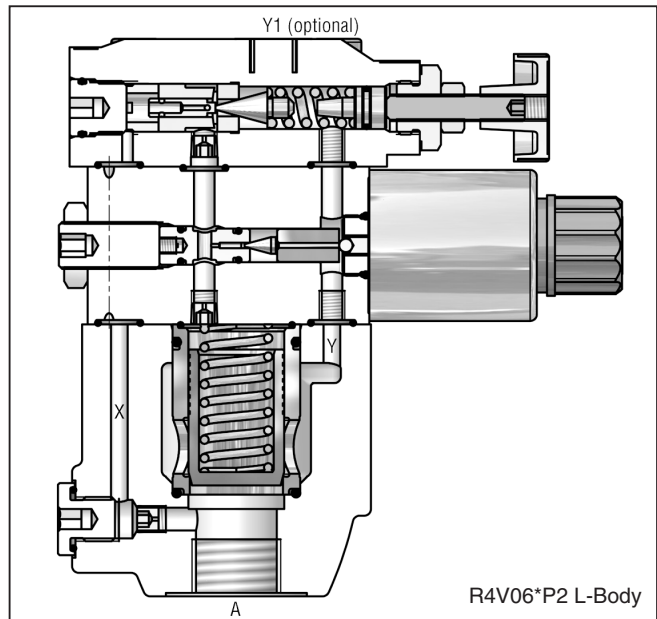
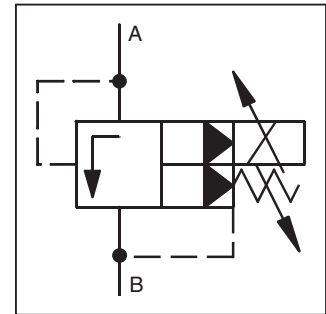
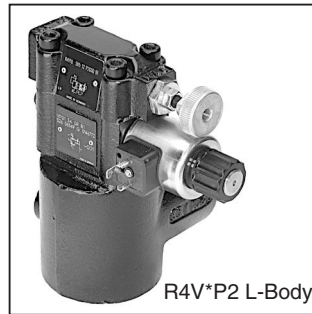

B

Features

- Pilot operated with manual adjustment.
- Continuous adjustment by proportional solenoid.
- 2 interfaces:
 - L-body (R4V06-G3/4", R4V10-G1 1/4")
 - T-body (R4V03-G1/2", R4V06-G1")
- 3 pressure ranges.
- With mechanical maximum pressure adjustment.

Specifications

General				
Size	T-Body		L-Body	
	03 (1/2")	06 (1")	06 (3/4")	10 (1-1/4")
Mounting	Threaded Body			
Mounting Position	Unrestricted			
Ambient Temp. Range	-20°C to +50°C (-4°F to +122°F)			
Hydraulic				
Max. Operating Pressure	Ports A and X up to 350 Bar (5075 PSI); Ports B and Y 30 Bar (435 PSI)			
Pressure Range	105 Bar (1523 PSI), 210 Bar (3045 PSI), 350 Bar (5075 PSI)			
Nominal Flow	60 LPM (15.9 GPM)	200 LPM (52.9 GPM)	200 LPM (52.9 GPM)	450 LPM (119.0 GPM)
Fluid	Hydraulic oil as per DIN 51524...51535, other on request			
Fluid Temperature	-20°C to 80°C (-4°F to 176°F)			
Viscosity Permitted	10 to 380 cSt / mm ² /s (46 to 1761 SSU)			
Viscosity Recommended	30 to 80 cSt / mm ² /s (139 to 371 SSU)			
Filtration	ISO Class 4406 (1999) 18/16/13 (acc. NAS 1638: 7)			
Electrical (Proportional Solenoid)				
Duty Ratio	100% ED; CAUTION: Coil temperature up to 150°C (302°F) possible			
Nominal Voltage	12 VDC			
Max. Current	2.3 amps			
Coil Resistance	4 Ohm at 20°C (68°F)			
Protection Class	IP65 in accordance with EN60529 (plugged and mounted)			
Power Amplifier	PCD00A-400			

Ordering Information

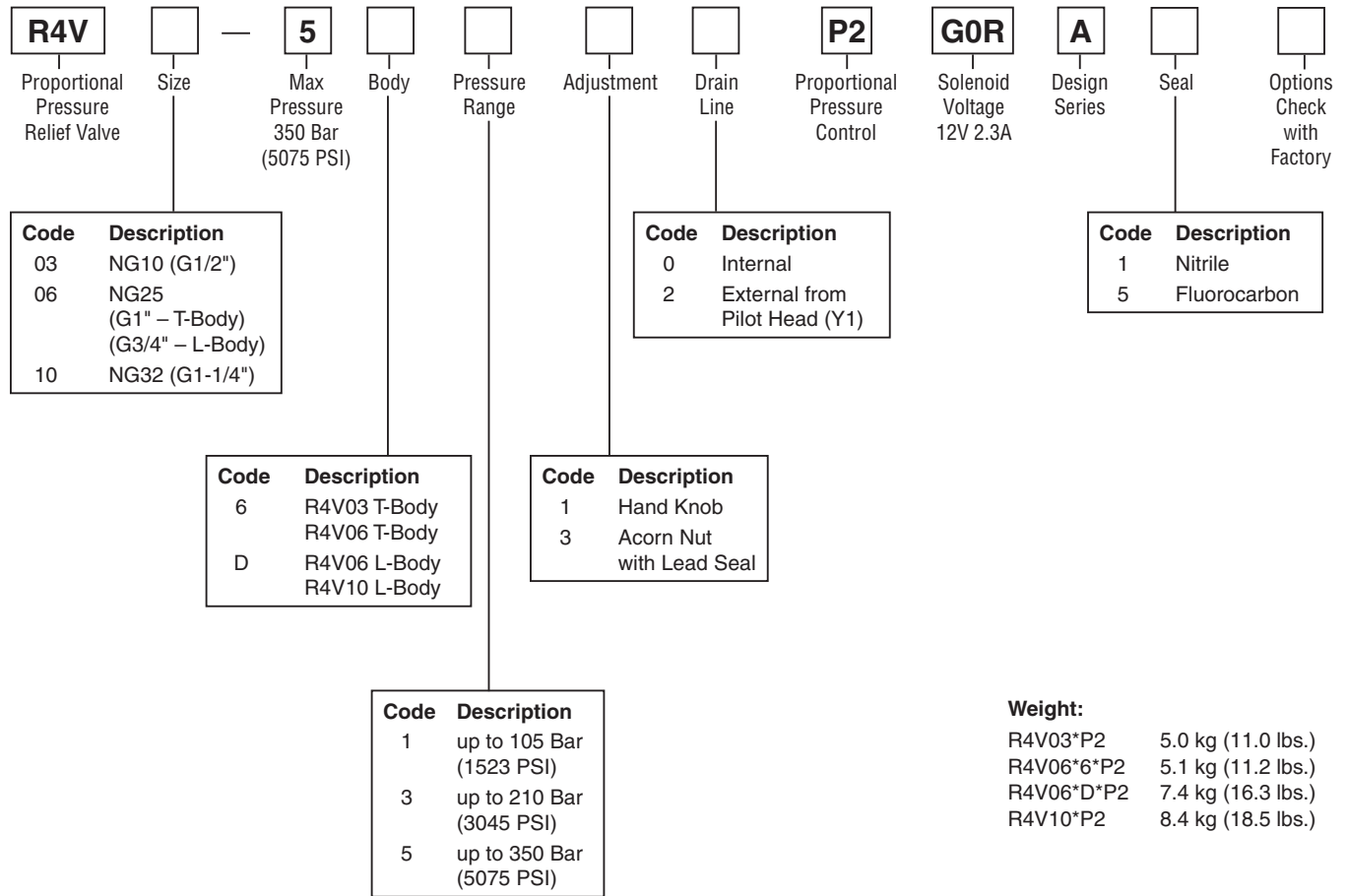

Performance Curve

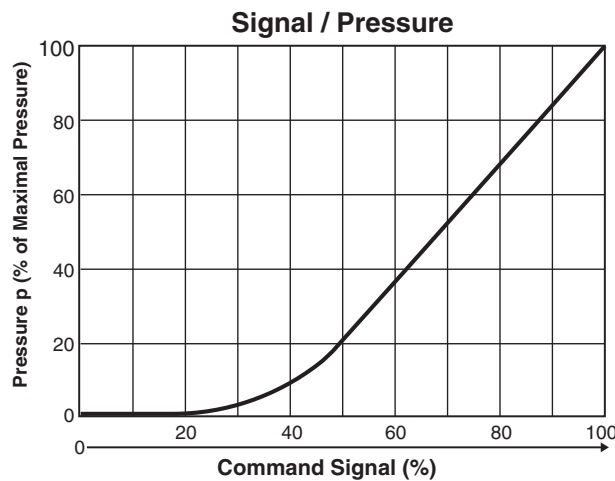

B

R4V03*P2 ¹⁾

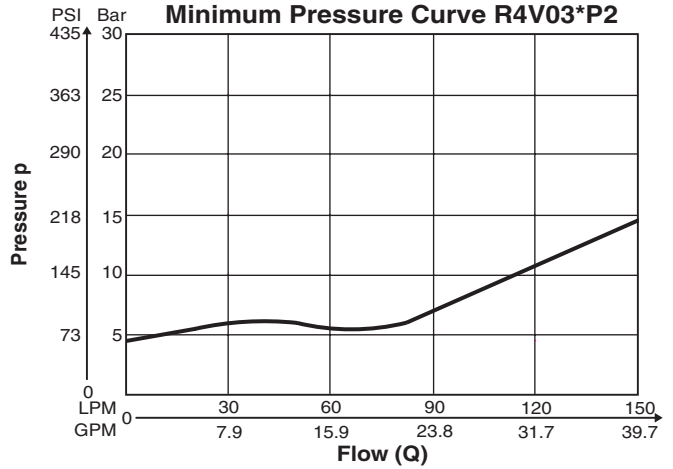
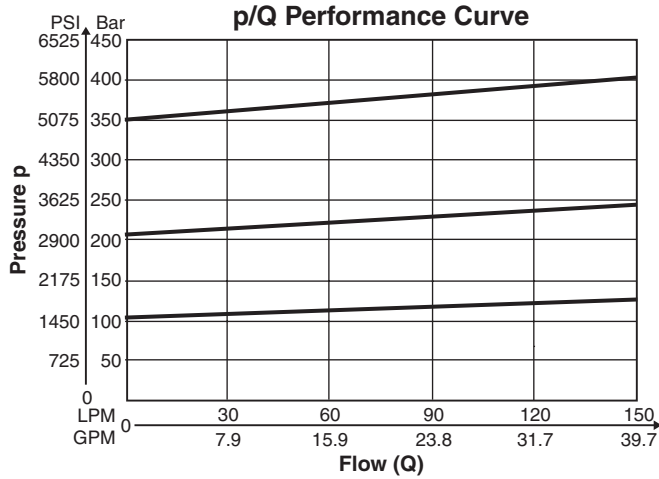

R4V06*P2 ¹⁾

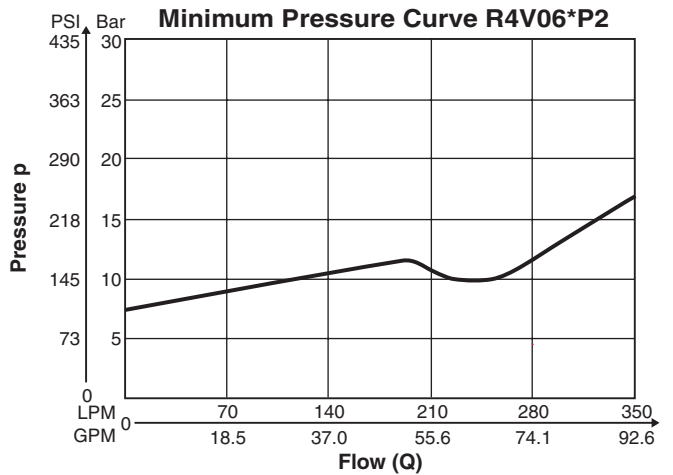
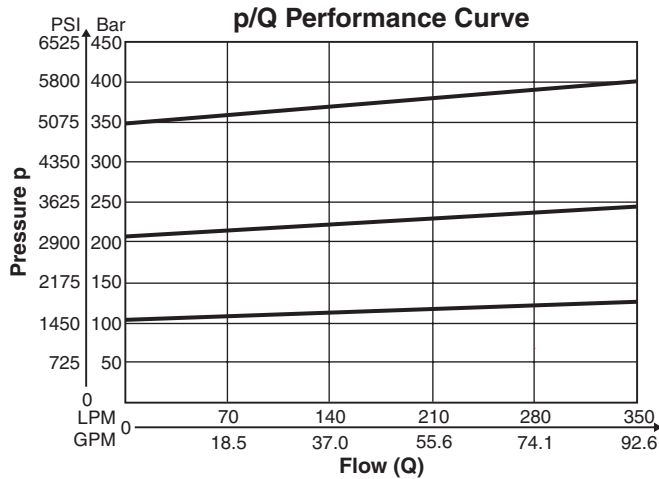

R4V10*P2 ¹⁾

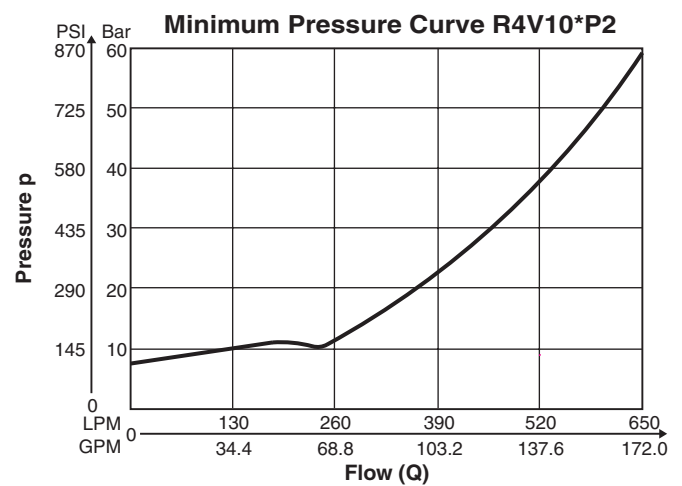
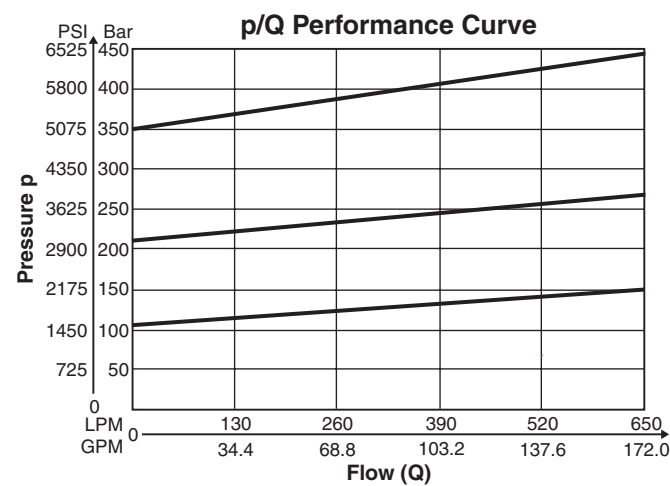

¹⁾ The performance curves are measured with external drain.
 For internal drain, the tank pressure has to be added to the curve.

T-Body

Inch equivalents for millimeter dimensions are shown in (**)

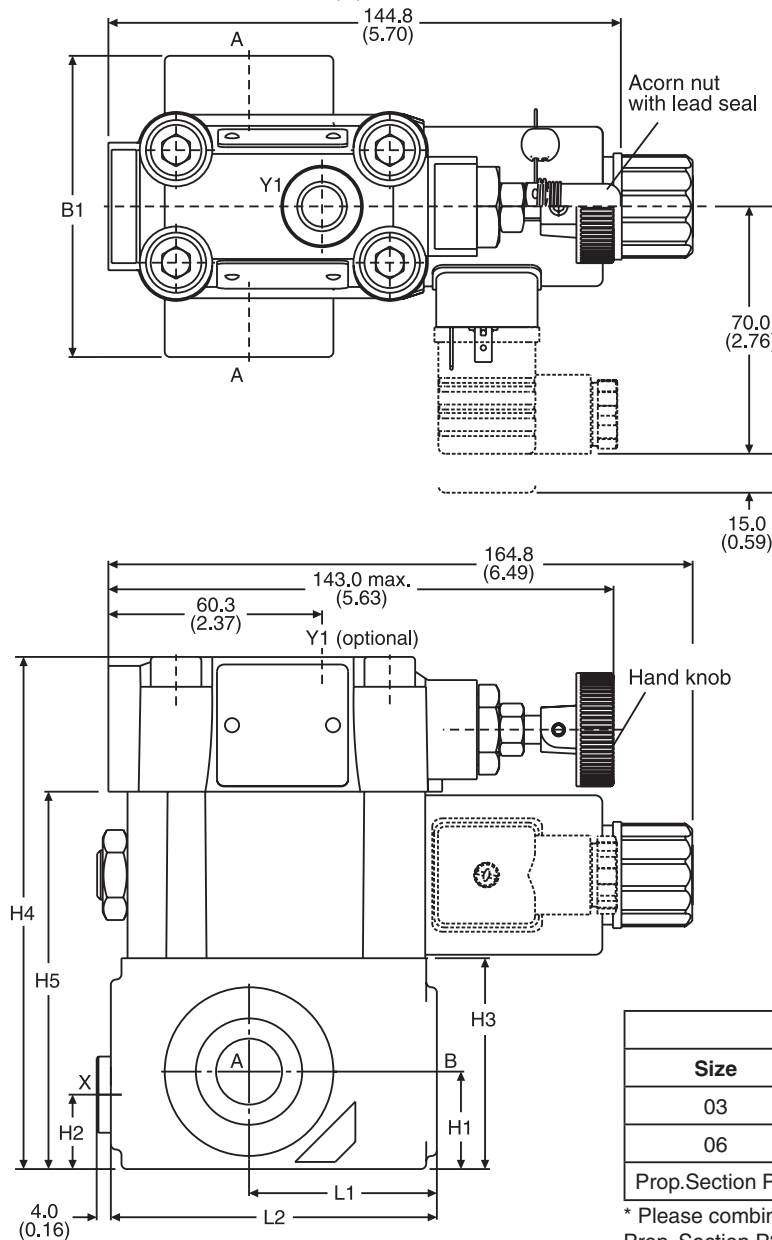

B

Seal Kits		
Size	Nitrile	Fluorocarbon
03	S26-58507-0	S26-58507-5
06	S26-58475-0	S26-58475-5
Prop. Section P2*	S26-58473-0	S26-58473-5

* Please combine seal kit of one size with seal kit of Prop. Section P2 for complete seal kit.

Size	Body	B1	H1	H2	H3	H4	H5	L1	L2
03	T-body	85.0 (3.35)	27.5 (1.08)	21.0 (0.83)	59.5 (2.34)	144.5 (5.69)	106.5 (4.19)	53.0 (2.09)	92.0 (3.62)
06	T-body	136.0 (5.35)	38.0 (1.50)	28.0 (1.10)	93.0 (3.66)	178.0 (7.01)	140.0 (5.51)	66.5 (2.62)	117.5 (4.63)

Ports	Function	Port Size	
		R4V03*P2 T-body	R4V06*P2 T-body
A	Pressure (inlet)	G1/2"	G1"
B	Tank (outlet)	G1/2"	G1"
X ¹⁾	Ext. Remote Control or Vent Connection	G1/4"	
Y1 ²⁾	External Drain	G1/4"	

¹⁾ Closed when supplied

²⁾ Port Y1 is only available at drain line (code 2) external from the pilot head

L-Body

Inch equivalents for millimeter dimensions are shown in (**)

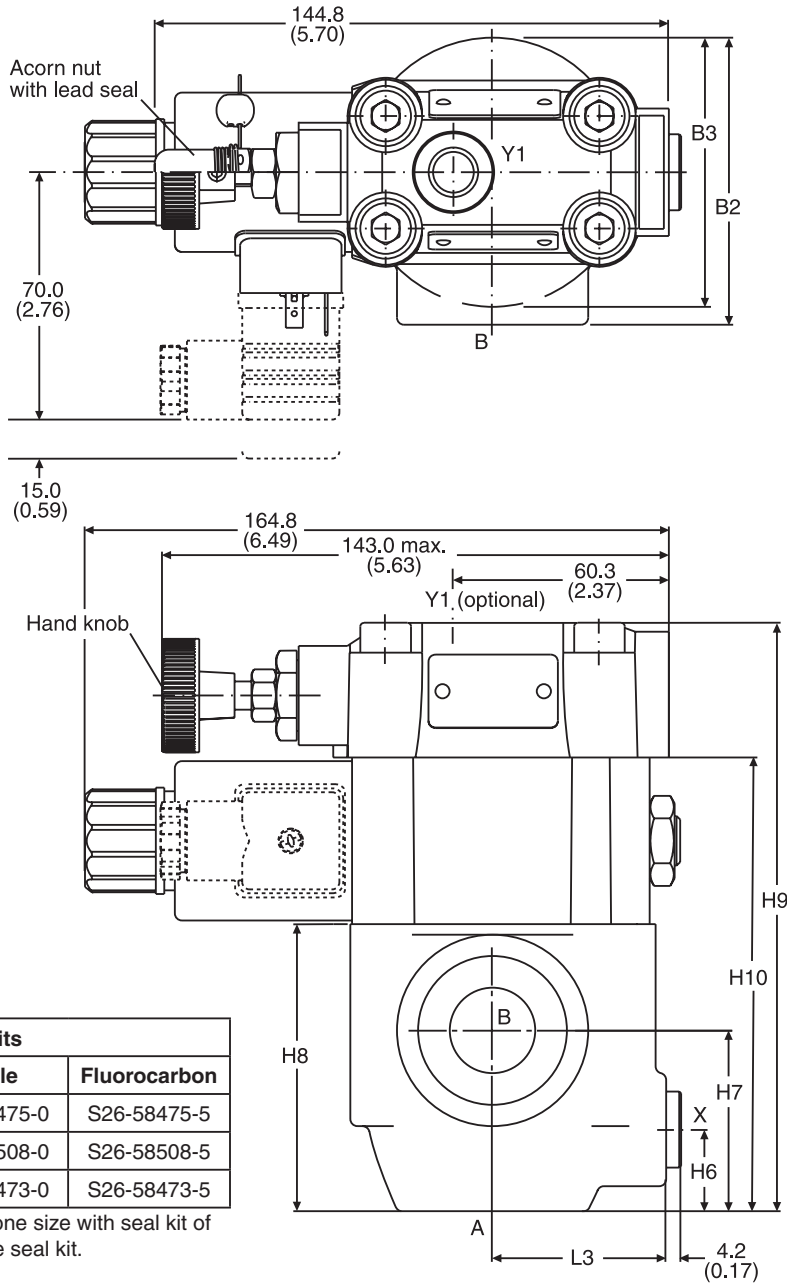

Seal Kits		
Size	Nitrile	Fluorocarbon
06	S26-58475-0	S26-58475-5
10	S26-58508-0	S26-58508-5
Prop. Section P2*	S26-58473-0	S26-58473-5

* Please combine seal kit of one size with seal kit of Prop. Section P2 for complete seal kit.

Size	Body	B2	B3	H6	H7	H8	H9	H10	L3
06	L-body	81.0 (3.19)	76.0 (2.99)	23.0 (0.91)	51.0 (2.01)	81.0 (3.19)	166.0 (6.54)	128.0 (5.04)	49.0 (1.93)
10	L-body	120.7 (4.75)	85.8 (3.38)	31.8 (1.25)	50.8 (2.00)	96.0 (3.78)	181.0 (7.13)	143.0 (5.63)	49.8 (1.96)

Ports	Function	Port size	
		R4V06 L-body	R4V10 L-body
A	Pressure (inlet)	G3/4"	G1-1/4"
B	Tank (outlet)	G3/4"	G1-1/4"
X ¹⁾	Ext. Remote Control or Vent Connection	G1/4"	
Y1 ²⁾	External Drain	G1/4"	

¹⁾ Closed when supplied

²⁾ Port Y1 is only available at drain line (code 2) external from the pilot head